

# VC4, VC6, VC8

Saniflo™ Series **METAL** Pumps

# EOM

Engineering  
Operation &  
Maintenance



Refine your process



**SANIFLO™ VC**  
SANITARY PUMP TECHNOLOGY

# C.A.T.



**TABLE OF CONTENTS**

**SECTION 1 CAUTIONS—READ FIRST! .....1**

**SECTION 2 CAT PUMP DESIGNATION SYSTEM .....2**

**SECTION 3 HOW IT WORKS—PUMP & AIR DISTRIBUTION SYSTEM .....3**

**SECTION 4 DIMENSIONAL DRAWINGS .....4**

**SECTION 5 SUGGESTED INSTALLATION, OPERATION & TROUBLESHOOTING .....5**

**SECTION 6 ASSEMBLY / DISASSEMBLY .....8**

**SECTION 7 EXPLODED VIEW & PARTS LISTING**

    A. SANIFLO™ VC4 .....12

    B. SANIFLO™ VC6 .....14

    C. SANIFLO™ VC8 .....16

**SECTION 8 DIRECTIONS FOR CONTROL PANEL POWER HOOKUP .....18**

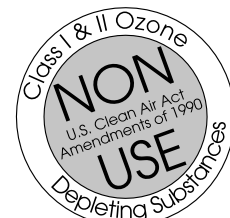

## CAUTIONS—READ FIRST!

- TEMPERATURE LIMITS:**  
 Buna-N      -12.2°C to 82.2°C    10°F to 180°F  
 Teflon® PTFE    4.4°C to 104.4°C    40°F to 220°F
  
- CAUTION:** Verify the chemical compatibility of the process and cleaning fluid to the pump's component materials in the Chemical Resistance Guide
  
- CAUTION:** When choosing pump materials, be sure to check the temperature limits for all components.
  
- CAUTION:** Maximum temperature limits are based upon mechanical stress only. Certain chemicals will significantly reduce maximum safe operating temperatures. Consult engineering guide for chemical compatibility and temperature limits.
  
- WARNING:** Prevention of static sparking – If static sparking occurs, fire or explosion could result. Pump, piping, and containers must be properly grounded whenever discharge of static electricity is a hazard.
  
- DO NOT OPERATE PUMP WITHOUT PROPER GROUND!** It is very important that the control panel is properly grounded for safe and proper operation. Do not reverse the hot and neutral wire under any circumstance. Unit may cause severe electric shock if used or installed improperly.
  
- CAUTION:** Disconnect all power sources prior to opening control panel. Never operate pump without control panel lid securely closed.
  
- CAUTION:** Vibration and shock to the control panel should be avoided.
  
- CAUTION:** Unit is designed to be powered by 110 VAC or 220 VAC only. The control panel incorporates an automated transformer that can handle the following power supply options: 110V AC - 50Hz, 110V AC - 60 Hz, 220V AC - 50 Hz, 220V AC - 60 Hz.
  
- CAUTION:** The Saniflo™ VC pump is not submersible. Mount control panel where it is not directly in the wash down area.
  
- CAUTION:** Always wear safety glasses when operating pump. If rupture of wetted components occurs, material being pumped may be forced from pump and may create a hazardous situation.
  
- CAUTION:** Before any maintenance or repair is attempted, the compressed air line to the pump should be disconnected and all air pressure allowed to bleed from pump. Disconnect all intake, discharge and air lines. Power down the control panel and disconnect it from electrical source. Drain the pump by disconnecting the hopper, sanitary tubing, fittings and check valves allowing any fluid to flow into a suitable container.
  
- CAUTION:** Do not exceed 8.6 Bar (125 psig) air supply pressure. Minimum air supply pressure required for operation is 1.7 bar (25 psig).
  
- CAUTION:** Blow out air line for 10 to 20 seconds before attaching to the regulator mounted to the control panel.
  
- CAUTION:** Only install pump as per the installation diagram (see section 5).
  
- CAUTION:** Ensure that hopper is not higher than top of vertical column. When pump is unpowered liquid will seek its own level and cause damage to controls.
  
- CAUTION:** When connecting the pump to any type of hopper, never place flex hose into the hopper from the topside. The hopper should always be connected to the pump from the bottom using sanitary tubing and fittings.
  
- CAUTION:** Tighten all clamp bands at regular intervals to ensure product containment. Fittings may loosen due to vibration.
  
- CAUTION:** In certain applications the Saniflo™ VC pump may have to be primed to start the pump. Applications that may require priming include breast, thigh meat, tenders and other extremely thick products. The pump can be primed by placing a plastic bag over the discharge port of the pump.
  
- WARNING:** To prevent contamination of process media with contaminated air, the inlet air filter cartridge must be changed when indicator button moves into the "Up" position (see figures 1 & 2). Use part # 80-0099.

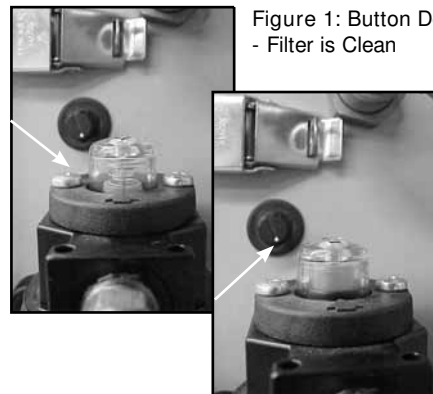

Figure 1: Button Down - Filter is Clean

Figure 2: Button Up - Change Filter



CAT PUMP DESIGNATION SYSTEM

SANIFLO™ VC

LEGEND

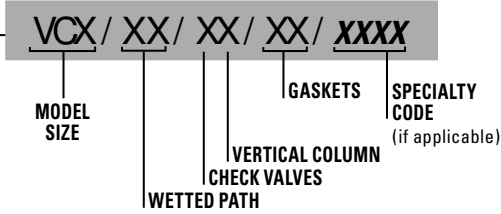

MATERIAL CODES

MODEL SIZE

VC4 = 76 mm (3") Inlet  
and 76 mm (3") Discharge  
VC6 = 102 mm (4") Inlet  
and 102 mm (4") Discharge  
VC8 = 152 mm (6") Inlet  
and 102 mm (4") Discharge

WETTED PATH

SS = 304 Stainless Steel

CHECK VALVES

S = 304 Stainless Steel Flapper

VERTICAL COLUMN

S = 304 Stainless Steel

GASKETS

FB = FDA Buna-N  
TF = PTFE (White)

| Item #  | Pump Description             | Max. Solids Passage | Inlet Dim.  | Outlet Dim. | Est. Shipping Wt. |
|---------|------------------------------|---------------------|-------------|-------------|-------------------|
| 80-1000 | VC4/SS/SS/FB/07 <sup>2</sup> | 76.2 mm (3")        | 76 mm (3")  | 76 mm (3")  | 41.7 kg (92 lbs)  |
| 80-1002 | VC4/SS/SS/TF/072             | 76.2 mm (3")        | 76 mm (3")  | 76 mm (3")  | 41.7 kg (92 lbs)  |
| 80-1004 | VC6/SS/SS/FB/072             | 101.6 mm (4")       | 102 mm (4") | 102 mm (4") | 48.9 kg (108 lbs) |
| 80-1006 | VC6/SS/SS/TF/072             | 101.6 mm (4")       | 102 mm (4") | 102 mm (4") | 48.9 kg (108 lbs) |
| 80-1008 | VC8/SS/SS/FB/072             | 152.4 mm (6")       | 125 mm (6") | 102 mm (4") | 69.9 kg (154 lbs) |
| 80-1010 | VC8/SS/SS/TF/072             | 152.4 mm (6")       | 125 mm (6") | 102 mm (4") | 69.9 kg (154 lbs) |
| 80-1011 | VC8/SS/SS/FB/073             | 152.4 mm (6")       | 125 mm (6") | 125 mm (6") | 69.9 kg (154 lbs) |
| 80-1012 | VC8/SS/SS/TF/073             | 152.4 mm (6")       | 125 mm (6") | 125 mm (6") | 69.9 kg (154 lbs) |

SPECIALTY CODES

072 = Saniflo™ USDA  
073 = Saniflo™ USDA  
w/152 mm (6") DISCHARGE  
(VC8 ONLY)

## HOW IT WORKS—PUMP

The CAT Saniflo™ pump is an air operated, positive displacement, electrically controlled pump. These drawings show the flow pattern through the pump upon its initial stroke. It is assumed the pump has no fluid in it prior to its initial stroke.

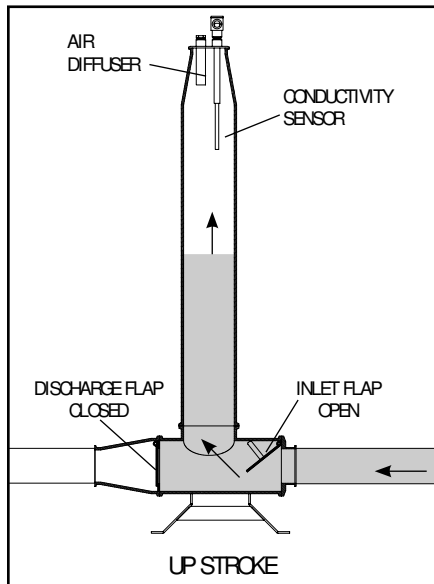

FIGURE 1 Once the control panel is turned on, the compressed air supplied to the panel is directed to the vacuum generator(s) located within the control panel. The vacuum generated by the vacuum generator(s) is applied to the vertical column of the Saniflo™ VC pump. This vacuum removes atmospheric pressure from the vertical column drawing the process medium into the pump past the inlet flap valve and into the vertical column. The process medium will continue to rise within the vertical column of the pump until the process medium reaches the conductivity sensor in the pump cap assembly.

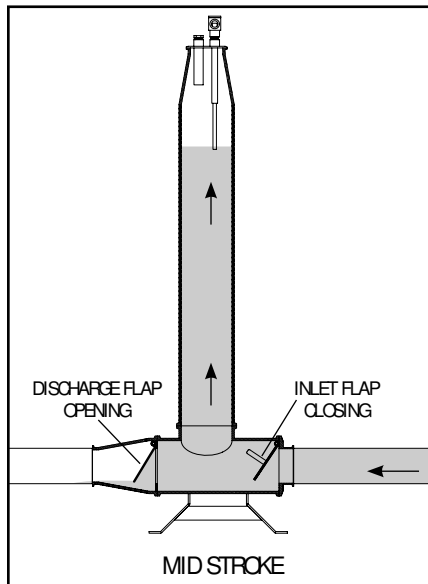

FIGURE 2 Once the process medium reaches the conductivity sensor at the top of the vertical column, the control panel senses the process medium and changes the direction of the air flow. Now the compressed air supplied to the controller is switched away from the internal vacuum generator(s) and directed into the vertical column of the pump. Once the compressed air is supplied to the top of the process medium, the hydraulic force will discharge the process medium from the vertical column. These same forces will close the inlet flap valve and open the discharge flap valve simultaneously causing the process medium to move downstream.

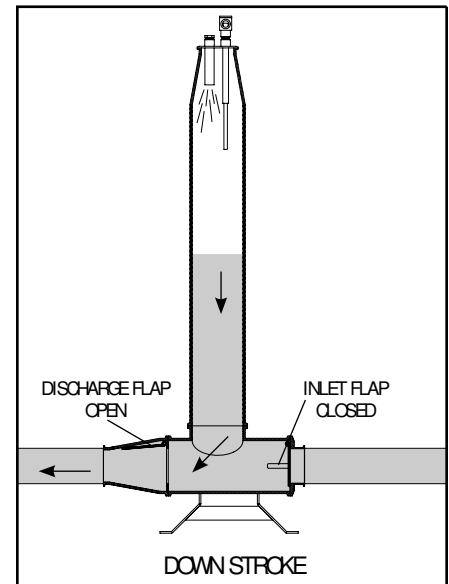
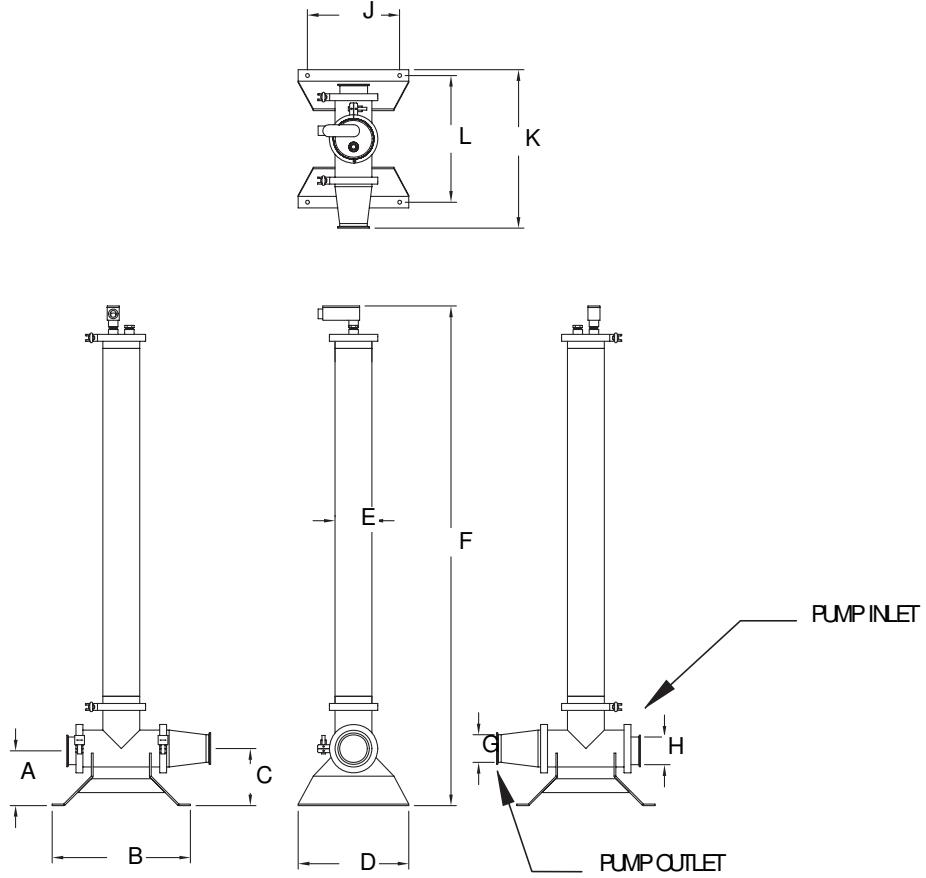

FIGURE 3 The discharge stroke length is controlled by the timer dial located on the right side of the Saniflo™ VC control panel. By adjusting the timer dial, the length of the time the compressed air is supplied directly to the process medium within the vertical column can be adjusted. Once the time has been set, the compressed air will be directed onto the process medium for the set time and then the control panel will redirect the air to the vacuum generator(s). Once air is redirected to the vacuum generator(s) the process medium is once again drawn up the vertical column towards the conductivity sensor. This constitutes one complete pumping cycle.

DIMENSIONAL DRAWINGS

SANIFLO<sup>™</sup> VC



| DIMENSIONS – SANIFLO <sup>™</sup> VC |             |                 |             |                 |             |                 |
|--------------------------------------|-------------|-----------------|-------------|-----------------|-------------|-----------------|
| ITEM                                 | VC4         |                 | VC6         |                 | VC8         |                 |
|                                      | METRIC (mm) | STANDARD (inch) | METRIC (mm) | STANDARD (inch) | METRIC (mm) | STANDARD (inch) |
| A                                    | 150         | 5.93            | 184         | 7.25            | 209         | 8.25            |
| B                                    | 381         | 15              | 381         | 15              | 381         | 15              |
| C                                    | 157         | 6.18            | N/A         | N/A             | N/A         | N/A             |
| D                                    | 304         | 12              | 304         | 12              | 304         | 12              |
| E                                    | 101         | 4               | 152         | 6               | 203         | 8               |
| F                                    | 1377        | 54.25           | 1423        | 56.06           | 1489        | 58.62           |
| G                                    | 76          | 3               | 101         | 4               | 102         | 4               |
| H                                    | 76          | 3               | 101         | 4               | 152         | 6               |
| J                                    | 254         | 10              | 254         | 10              | 254         | 10              |
| K                                    | 436         | 17.18           | 555         | 21.87           | 647         | 25.50           |
| L                                    | 352         | 13.87           | 352         | 13.87           | 352         | 13.87           |



**SUGGESTED INSTALLATION**

The pipe size should be at least the size of the inlet and discharge ports of the pump or larger if highly viscous material is being pumped. The suction hose must be non-collapsible, reinforced type as the SANIFLO™ VC pump is capable of pulling a vacuum. It is critical that all fittings and connections are airtight or a reduction or loss of pump suction capability will result.

**INSTALLATION:** Months of careful planning, study and selection efforts can result in unsatisfactory pump performance if installation details are left to chance.

Premature failure and long term dissatisfaction can be avoided if reasonable care is exercised throughout the installation process.

**LOCATION:** Noise, safety and other logistical factors usually dictate where equipment should be situated on the production floor. Multiple installations with conflicting requirements can result in congestion of utility areas, leaving few choices for additional pumps.

Within the framework of these and other existing conditions, every pump should be located in such a way that six key factors are balanced against each other to maximum advantage.

**ACCESS:** First, the location should be accessible. If it is easy to reach the pump, maintenance personnel will have an easier time carrying out routine inspections and adjustments. Should major repairs become necessary, ease of access can play a key role in speeding the repair process and reducing total downtime. Verify that the site also allows for ease of cleaning and proper drainage during wash down.

**AIR SUPPLY:** Every pump installation should use an air line large enough to supply the volume of air necessary to achieve the desired pumping rate. Use air pressure up to a maximum of 8.6 bar (125 psig) depending on pumping requirements. The minimum air pressure required to effectively operate the pump is 1.7 bar (25 psig).

**ELECTRICAL:** All pump control panels come equipped with 110V AC/220V AAC, 50/60 Hz capabilities. See page 18 for details on connecting panel to power source.

**ELEVATION:** Selecting a site that is well within the pump's dynamic lift capability will assure that loss-of-prime troubles will be eliminated. In addition, pump efficiency can be adversely effected if proper attention is not given to site location.

**PIPING:** Final determination of pump site should not be made until the piping problems of each possible location have been evaluated. The impact of current installations should be considered ahead of time to make sure that inadvertent restrictions are not created for any remaining sites.

The best choice possible will be a site involving the shortest and straightest hook-up of suction and discharge piping. Unnecessary elbows, bends and fittings should be avoided. Pipe sizes should be selected to keep friction losses within practical limits. All piping should be supported independently of the pump. In addition, the piping should be aligned to avoid placing stresses on the pump fittings.

If the pump is to be bolted down to a solid location, a mounting pad placed between the pump stand and the foundation will assist in minimizing pump vibration.

The proper orientation for this SANIFLO™ VC pump is to have the vertical column in the vertical position.

**SOLIDS PASSAGE CAPABILITIES:**

|     |              |
|-----|--------------|
| VC4 | 7.6 cm (3")  |
| VC6 | 10.2 cm (4") |
| VC8 | 15.2 cm (6") |

**CONNECTING PUMP TO CONTROL PANEL:** The control panel should be connected to the pump as close as possible without putting the control panel in harms way. The control panel comes complete with seven feet of hose to connect the control panel to the pump. The control panel may be mounted farther from the pump than seven feet, but this will decrease the capacity of the pump slightly. Moving the control panel farther away will also increase the air consumption by approximately 5% for every additional ten feet of air tubing. The sanitary cap which houses the probe and air diffuser is placed on top of the vertical column and secured by a four inch sanitary clamp. Your pump is now connected to the control panel.

**CONNECTING PUMP TO HOPPER:** The correct way to connect the hopper to the pump is from the bottom of the hopper using sanitary pipe & fittings. **NOTE:** When connecting pump to any type of hopper, never place the flex hose into the hopper from the topside. The hopper should always be connected to the pump from the bottom of the hopper.

**REFER TO SECTION 6A  
(pages 8 and 9) FOR ASSEMBLY  
INSTRUCTIONS**

## SUGGESTED INSTALLATION

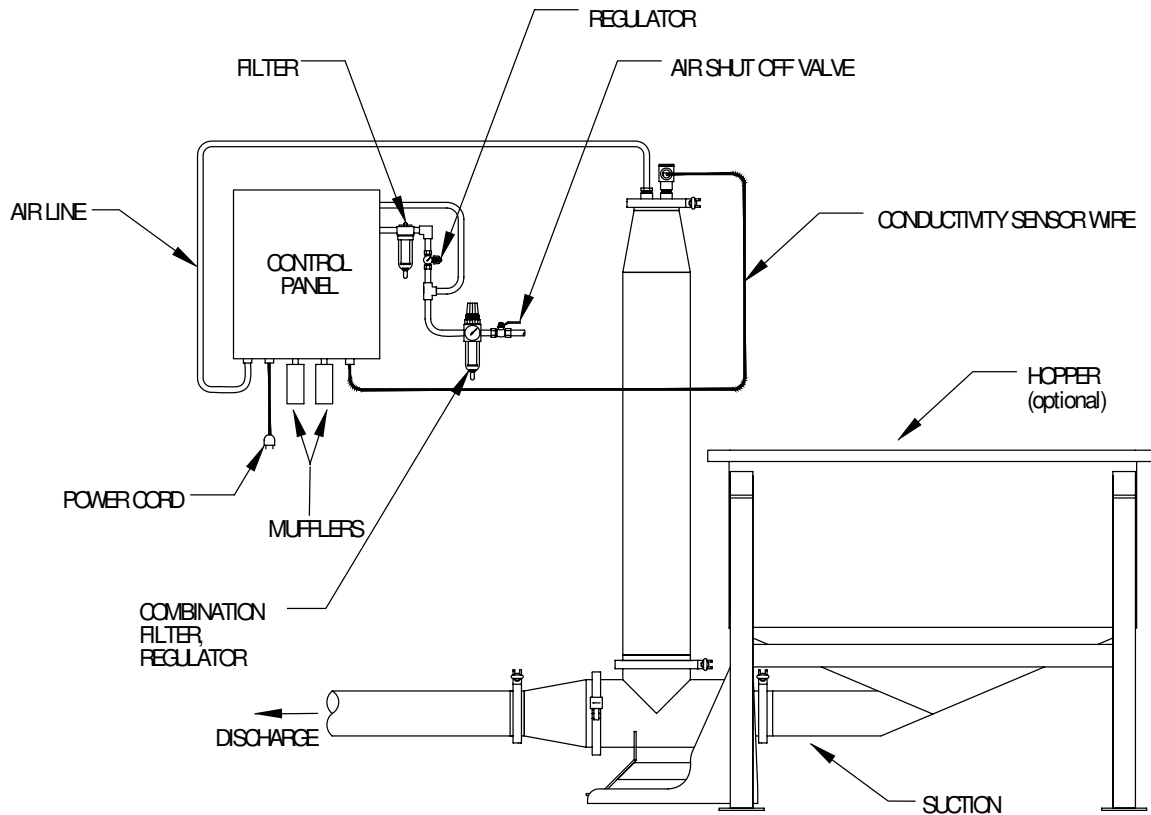

## SUGGESTED OPERATION & MAINTENANCE

**OPERATION:** The SANIFLO™ VC pump does not require inline lubrication.

### HOW TO OPERATE PUMP, STEPS 1 – 9:

1. Insert panel power cord into electrical outlet.
2. Ensure that ball valve located at large air regulator is in the off position.
3. Ensure both small and large air regulators are in the off position by turning the dial counter clockwise until hitting the stop.
4. Adjust small regulator approx. 6 turns clockwise.
5. Adjust timer dial to mid-point.
6. Adjust power switch to the on position (to the right)
7. Open ball valve located at large regulator.
8. Now begin adjusting the large regulator clockwise at which pump will begin to cycle at approx. 1.7 bar (25 psig).
9. Now system is ready for fine-tuning by adjusting both the small and large air regulators and timer dial to desired flow rate. **NOTE:** Turn timer dial counter clockwise to decrease discharge time interval and clockwise to increase discharge time interval.

### TO REMOVE PUMPING MEDIUM FROM PUMP:

Initiate process by continually pressing the system purge button on right side of panel. Continue pressing system purge button until product is completely removed from pump.

**MAINTENANCE AND INSPECTIONS:** Since each application is unique, maintenance schedules may vary for every pump. Frequency of use, viscosity and abrasive characteristics of process fluid all affect the parts life of a CAT pump. Periodic inspections have been found to offer the best means for preventing unscheduled pump downtime. Personnel familiar with the pump construction and service should be informed of any abnormalities that are detected during operation.

**NOTE:** Daily inspections of the inlet air regulator are recommended to ensure proper operating pressure. Also, inspect filter bowl daily to ensure longevity of filter elements. Monthly inspections of the diffuser are recommended to ensure consistent and adequate pumping volume. Also, inspect pressure differential indicator (red pop-up) located at top of filter to ensure filter is replaced when needed.

**Records:** When service is required, a record should be made of all necessary repairs and replacements. Over a period of time, such records can become a valuable tool for predicting and preventing future maintenance problems and unscheduled downtime. In addition, accurate records make it possible to identify pumps that are poorly suited to their applications.



## TROUBLESHOOTING – AIR CONTROLLED

Pump will not prime or pull vacuum when the control panel suction light is on.

1. Push discharge button on side of control panel for approximately two seconds. If this does not help, disassemble the pump and clear the check valves.
2. Verify whether or not the air is turned on and that the air pressure is 25 psig or greater.
3. Inspect inlet and discharge flap valves to determine whether or not the flap in the flap valve is adequately sealing against flap valve housing.
4. Disassemble and clean vacuum generator. If this does not work, replace vacuum generator unit.
5. Verify that all tubing or plumbing connections, both inside the control panel and at the pump, are seated properly and there are no evident signs of air leaking.
6. Verify proper alignment of flap valve assembly. The hinge of the flap valve is to be located at the top or the assembly (not at the bottom).

Pump is in suction mode (control panel suction light is on) and will not cycle to the discharge mode.

1. Verify whether or not fuse is bad. This can be done by inspecting the color of the fuse. If the fuse is brown or gray in color, the fuse most likely has failed at which a new fuse will need to be replaced.
2. Remove relay and inspect contacts, clean contacts and replace relay. If problem persists replace relay.
3. Verify adequate probe connections at both ends of wiring.
4. Clean probe in reservoir tube.

Control Panel Will Not Cycle

1. Ensure power is properly connected to transformer.
2. Ensure power switch is turned on.
3. Ensure all solenoid wires are connected.

**WARNING:** To prevent contamination of process media with contaminated air, the inlet air filter cartridge must be changed when indicator button moves into the "Up" position (see figures 1 & 2). Use part # 80-0099.



Figure 1: Button Down - Filter is Clean

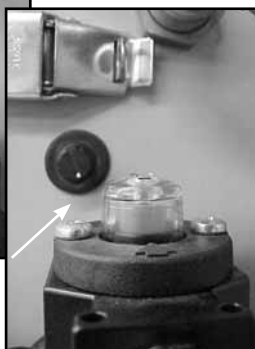

Figure 2: Button Up - Change Filter

Pump runs but little or no product flows.

1. Verify no obstructions or debris in wetted portion of pump or piping.
2. Verify whether or not the air is turned on and that the air pressure is 25 psig or greater.
3. Verify no interference at flap valve assembly.

Pump is in discharge mode (control panel discharge light is on) and will not cycle to suction mode.

1. Clean probe located at top of reservoir tube.
2. Verify adequate contact of terminal #6 wire on relay base (see control panel overview below).
3. Verify that both the relay base and terminal strip is free of corrosion (see control panel overview below).

Product comes out of pump joints.

1. Retighten all fasteners as required.
2. Replace all worn seals.

NOTE: Ensure that hopper is not higher than top of pump reservoir tube. When pump is unpowered liquid will seek its own level and cause damage to controls.

Control Panel Breakdown

- |                     |                 |
|---------------------|-----------------|
| 1. Vacuum Generator | 5. Timer Dial   |
| 2. Transformer      | 6. Purge Button |
| 3. Solenoid Valve   | 7. Power Switch |
| 4. Timer Relay      |                 |

### Control Panel

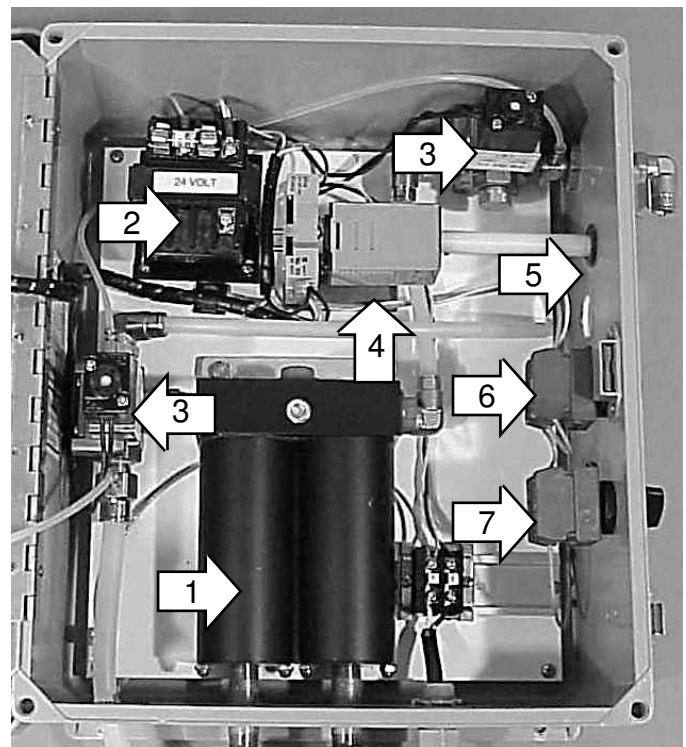

**DISASSEMBLY/REASSEMBLY**

**Tools Required:**

- 2 Adjustable Wrench
- Vise equipped with soft jaws (such as plywood, plastic or other suitable material)

**CAUTION:** Before any maintenance or repair is attempted, the compressed air line to the pump should be disconnected and all air pressure allowed to bleed from the pump. Disconnect all intake, discharge, and air lines. Drain the pump by turning it upside down and allowing any fluid to flow into a suitable container. Be aware of any hazardous effects of contact with your process fluid.

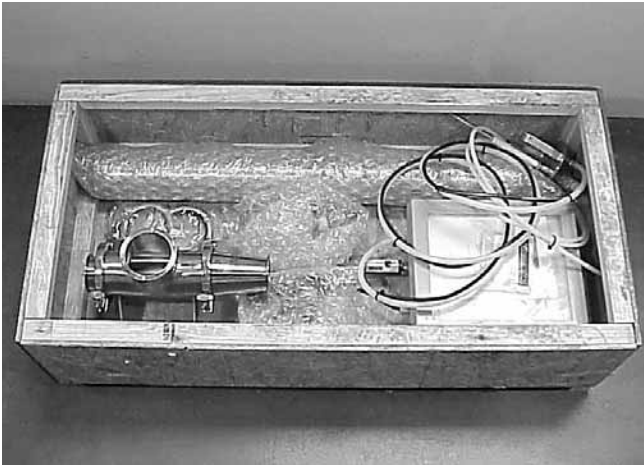

Step 1 Figure 1

Prior to assembly, confirm pump inventory (refer to parts matrix, VC4 pg. 13, VC6 pg. 15 and VC8 pg. 17). (Figure 1)

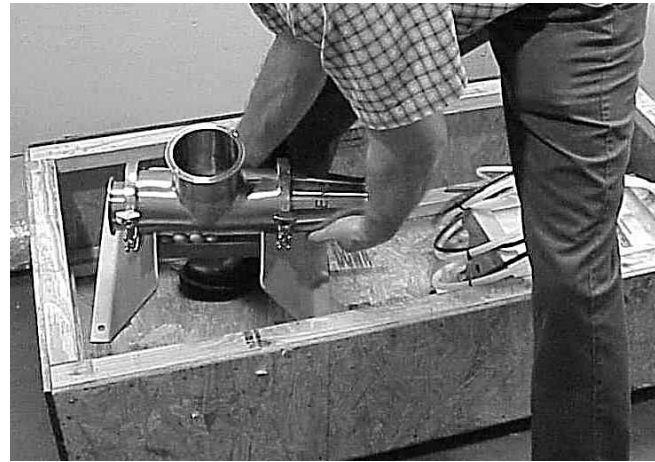

Step 2 Figure 2

Prior to assembly, carefully remove pump parts from box making sure not to damage components. (Figure 2)

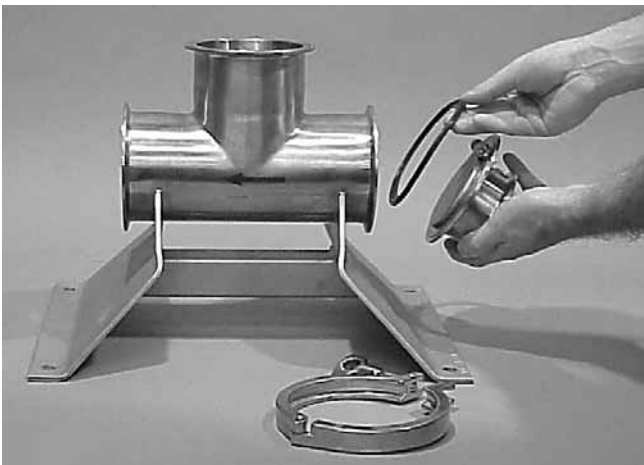

Step 3 Figure 3

Begin assembly by installing the flange gasket and inlet flap valve housing to pump base. After joining components, secure with clamp band. NOTE: When installing inlet flap valve housing, ensure that hinged portion of flap valve is located in the up position by utilizing the "UP" reference mark on the inlet housing. (Figure 3)



Step 4 Figure 4

Position flange gasket and discharge flap valve housing to pump base. After joining components, secure with clamp band. NOTE: When installing discharge flap valve housing, ensure that hinged portion of flap valve is located in the up position utilizing the "UP" marking on flange housing. (Figure 4)

## DISASSEMBLY/REASSEMBLY

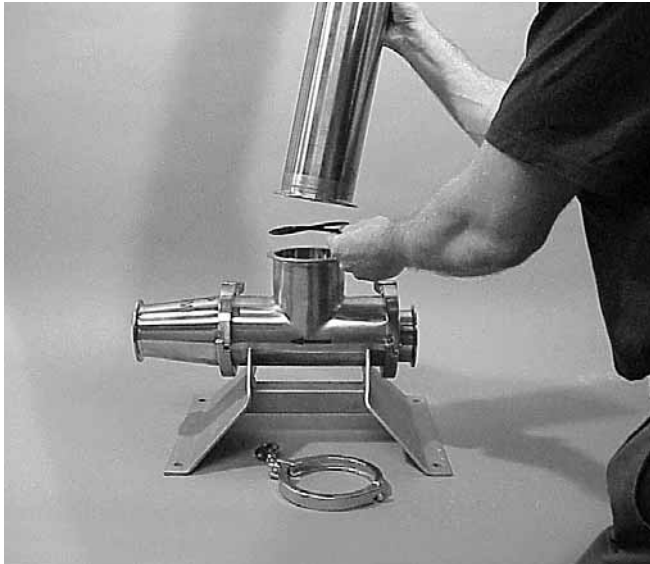

Step 5

Figure 5

Position flange gasket and vertical column to pump base. After joining components, secure with clamp band. (Figure 5)



Step 6

Figure 6

Position flange gasket and cap to vertical column. After joining components, secure with clamp band. (Figure 6)



Step 7

Figure 7

With the assembly process now complete, pump can be positioned into place and control panel mounted with suitable fasteners to appropriate substrate. (Figure 7)

**DISASSEMBLY/REASSEMBLY**

**CAUTION:** Before any maintenance or repair is attempted, the compressed air line to the pump should be disconnected. Be aware of the hazardous effects of contact with your process medium.

**NOTE:** The pipe pig option is designed to help clear the process lines of valuable product prior to cleaning. By installing the pipe pig T-section in the discharge line after the pump, the pipe pig can be inserted as shown prior to depressing the pump air purge button. We offers the pipe pig as a kit that includes everything for installation.

Kit, Pipe Pig, 3" 80-0012

Kit, Pipe Pig, 4" 80-0013



Step 1

Figure 1



Step 2

Figure 2

With a tee section installed downstream from pump but as close to discharge of pump as possible, insert pipe pig into tee section. NOTE: Pipe pig can be inserted into tee section either way, bolt or smooth side first. (Figure 1)

When inserting pipe pig into tee section, press backside of pipe pig. This will allow pipe pig to be easily maneuvered around the corner of the tee section. (Figure 2)



Step 3

Figure 3

After inserting pipe pig, install flange gasket and cap to tee section. After joining components, secure with clamp band. (Figure 3)

## DIRECTIONS FOR USE OF PIPE PIG

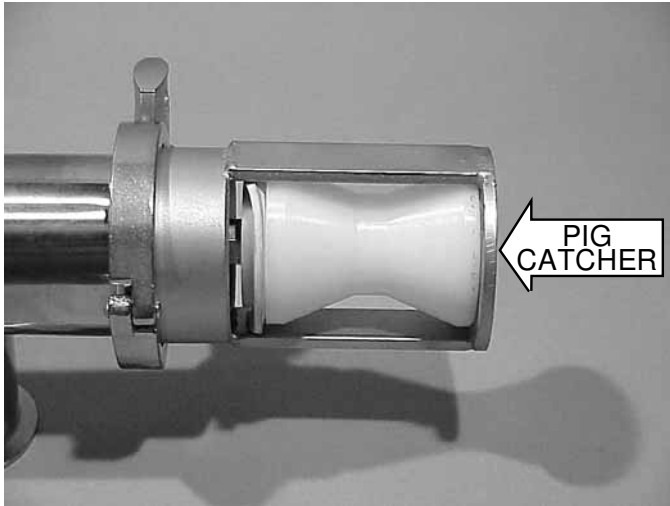

After securing tee section cap with clamp band, install pipe pig catcher to end of process discharge piping. When installation of pipe pig catcher is complete, begin purging process by continually pressing the system purge button on right side of control panel. When purging process is complete, retrieve pipe pig from pipe pig catcher. (Figure 4)

Step 4

Figure 4

## DIRECTIONS FOR USE OF HEATED CAP

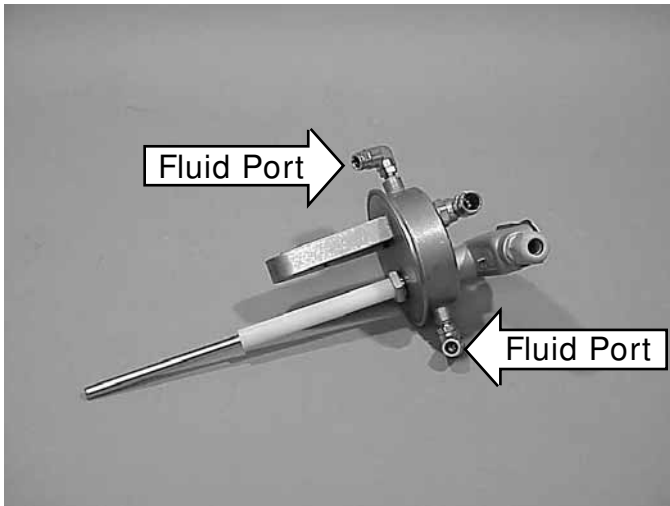

The heated cap option is designed for use in extremely cold or humid environments. The heater cap may be necessary to limit freezing at cap area. This heated cap is specifically designed to limit freezing in the vertical column due to the expansion of compressed air as it enters the column. Simply connect a hose to both liquid ports and continuously flush with warm water or steam. The warm water or steam counteracts the freezing condition inside the vertical column cap. The optional heated cap can be ordered using part #80-0088.

Figure 1

EXPLODED VIEW & PARTS LISTING

SANIFLO<sup>™</sup> VC4

EXPLODED VIEW

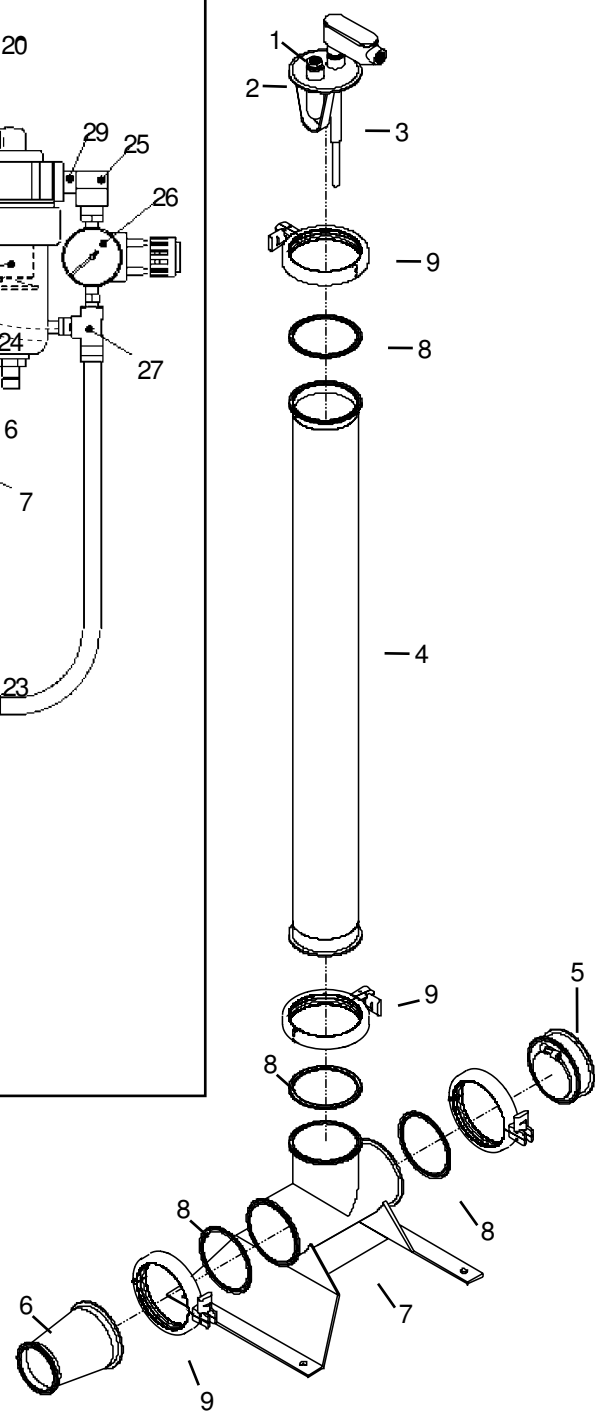
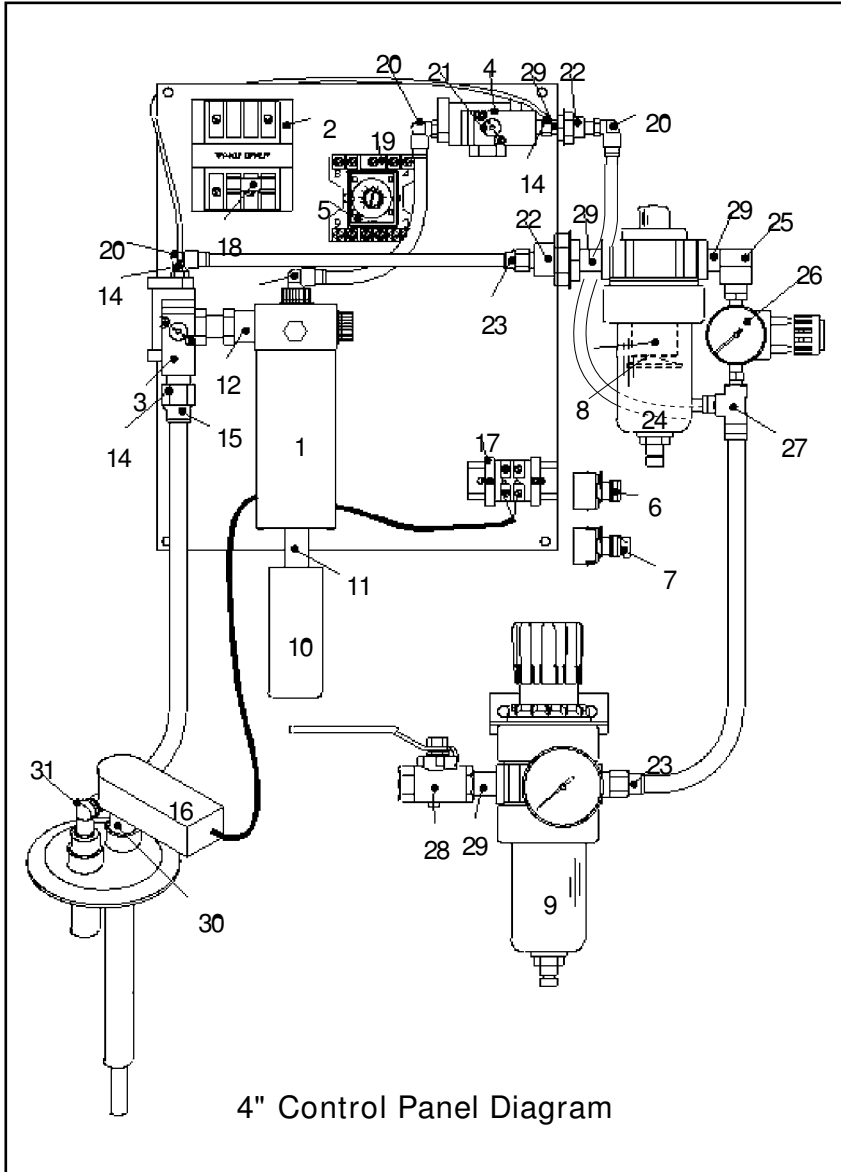

**EXPLODED VIEW & PARTS LISTING**

**SANIFLO<sup>TM</sup> VC4**

**PARTS LISTING**

| VC4 PUMP COMPONENTS |                                       |               |                      |                      |
|---------------------|---------------------------------------|---------------|----------------------|----------------------|
| Item                | Part Description                      | Qty. Per Pump | VC4/SS/SS/TF/072 P/N | VC4/SS/SS/FB/072 P/N |
| 1                   | Cap - A3 Sensor                       | 1             | 80-0087              | 80-0087              |
|                     | Cap - Water Heated Sensor (not shown) | optional      | 80-0088              | 80-0088              |
| 2                   | Diffuser - C2                         | 1             | 80-0094              | 80-0094              |
| 3                   | Probe                                 | 1             | 80-0116              | 80-0116              |
| 4                   | Tube - 4" Reservoir 40"               | 1             | 80-0127              | 80-0127              |
| 5                   | Valve, Inlet Check, 3" x 3"           | 1             | 80-0144              | 80-0144              |
| 6                   | Valve, Outlet, 4" x 3" Reducer        | 1             | 80-0145              | 80-0145              |
| 7                   | Base - 4" Pump                        | 1             | 80-0084              | 80-0084              |
| 8                   | Gasket - 4" FB Buna                   | 4             | N/A                  | 80-0101              |
| 8                   | Gasket - 4" Teflon                    | 4             | 80-0152              | N/A                  |
| 9                   | Clamp - 4" H.D.                       | 4             | 80-0089              | 80-0089              |

| VC4 CONTROL PANEL COMPONENTS |   |                |         |
|------------------------------|---|----------------|---------|
| Item                         | Part Description                        | Qty. Per Panel | P/N     |
| 1                            | Vacuum Generator - Single               | 1              | 80-0140 |
| 2                            | Transformer (24V)                       | 1              | 80-0126 |
| 3                            | Valve - 3-Way MAC,(PE) 24V              | 1              | 80-0142 |
| 4                            | Valve - 3-Way MAC,(PI) 24V              | 1              | 80-0143 |
| 5                            | Timer Relay (24V)                       | 1              | 80-0125 |
| 6                            | Switch - Purge, w/ n/o & n/c Contact    | 1              | 80-0121 |
| 7                            | Switch - On/Off Switch with n/o Contact | 1              | 80-0120 |
| 8                            | Coalescent Filter Cartridge             | 1              | 80-0091 |
| 9                            | Regulator - 3/8" Filter,150 psi w/Gage  | 1              | 80-0117 |
| 10                           | Muffler                                 | 1              | 80-0109 |
| 11                           | Nipple - 3/8"x2 1/2", Stainless         | 1              | 80-0114 |
| 12                           | Nipple - 1/2"x3/8", Brass Male Reducing | 1              | 80-0111 |
| 13                           | Tube,3/8"x1/8",NPTM,Swivel,90 Elbow     | 1              | 80-0132 |
| 14                           | Tube,5/32"x10/32,UNF,Male Connector     | 1              | 80-0138 |
| 15                           | Tube,1/2"x3/8",NPTM,Male Connector      | 3              | 80-0131 |
| 16                           | Elbow - 1/2" Alum Body                  | 1              | 80-0095 |
| 17                           | Terminal Strip Assembly                 | 1              | 80-0124 |
| 18                           | Fuse 250V, 2A                           | 1              | 80-0100 |
| 19                           | Relay Socket                            | 1              | 80-0119 |
| 20                           | Tube,3/8"x3/8",NPTM,Swivel,90 Elbow     | 3              | 80-0135 |
| 21                           | Plug - 3/8" Brass                       | 1              | 80-0115 |
| 22                           | Connector - 3/8" Brass Bulkhead         | 2              | 80-0092 |
| 23                           | Tube,3/8"x3/8",NPTM,Male Connector      | 1              | 80-0134 |
| 24                           | Filter - 3/8" Colescent                 | 1              | 80-0097 |
| 25                           | Elbow - 3/8" Brass Street 90            | 1              | 80-0096 |
| 26                           | Regulator - 3/8" w/gauge                | 1              | 80-0118 |
| 27                           | Tube,3/8"x3/8",NPTM,Swivel,Male Run Tee | 1              | 80-0136 |
| 28                           | Valve - 3/8" Brass Ball                 | 1              | 80-0141 |
| 29                           | Nipple - 3/8" Brass Close Hex           | 3              | 80-0113 |
| 30                           | Nipple - 1/2" Stainless Close           | 1              | 80-0110 |
| 31                           | Tube, 1/2"x1/2", NPT, 90 Elbow          | 1              | 80-0130 |





**EXPLODED VIEW & PARTS LISTING**

**SANIFLO<sup>TM</sup> VC6**

**PARTS LISTING**

| VC6 PUMP COMPONENTS |                                       |               |                      |                      |
|---------------------|---------------------------------------|---------------|----------------------|----------------------|
| Item                | Part Description                      | Qty. Per Pump | VC6/SS/SS/TF/072 P/N | VC6/SS/SS/FB/072 P/N |
| 1                   | Cap - A3 Sensor                       | 1             | 80-0087              | 80-0087              |
|                     | Cap - Water Heated Sensor (not shown) | optional      | 80-0088              | 80-0088              |
| 2                   | Diffuser - C2                         | 1             | 80-0094              | 80-0094              |
| 3                   | Probe                                 | 1             | 80-0116              | 80-0116              |
| 4                   | Tube - 6" Reservoir                   | 1             | 80-0128              | 80-0128              |
| 5                   | Valve, Inlet Check, 6" x 4"           | 1             | 80-0146              | 80-0146              |
| 6                   | Valve, Outlet, 6" x 4" Reducer        | 1             | 80-0147              | 80-0147              |
| 7                   | Base - 6" Pump                        | 1             | 80-0085              | 80-0085              |
| 8                   | Gasket - 4" FB Buna                   | 1             | N/A                  | 80-0101              |
| 8                   | Gasket - 4" Teflon                    | 1             | 80-0152              | N/A                  |
| 9                   | Gasket - 6" FB Buna                   | 3             | N/A                  | 80-0102              |
| 9                   | Gasket - 6" Teflon                    | 3             | 80-0153              | N/A                  |
| 10                  | Clamp - 4" HD                         | 1             | 80-0089              | 80-0089              |
| 11                  | Clamp - 6" HD                         | 3             | 80-0090              | 80-0090              |

| VC6 CONTROL PANEL COMPONENTS |   |                |         |
|------------------------------|---|----------------|---------|
| Item                         | Part Description                        | Qty. Per Panel | P/N     |
| 1                            | Vacuum Generator - Double               | 1              | 80-0139 |
| 2                            | Transformer (24V)                       | 1              | 80-0126 |
| 3                            | Valve - 3-Way MAC,(PE) 24V              | 1              | 80-0142 |
| 4                            | Valve - 3-Way MAC,(PI) 24V              | 1              | 80-0143 |
| 5                            | Timer Relay (24V)                       | 1              | 80-0125 |
| 6                            | Switch - Purge, w/ n/o & n/c Contact    | 1              | 80-0121 |
| 7                            | Switch - On/Off Switch with n/o Contact | 1              | 80-0120 |
| 8                            | Coalescent Filter Cartridge             | 1              | 80-0091 |
| 9                            | Regulator - 3/8" Filter,150 psi w/Gage  | 1              | 80-0117 |
| 10                           | Muffler                                 | 2              | 80-0109 |
| 11                           | Nipple - 3/8"x2 1/2", Stainless         | 2              | 80-0114 |
| 12                           | Nipple - 1/2"x3/8", Brass Male Reducing | 1              | 80-0111 |
| 13                           | Tube,3/8"x1/8",NPTM,Swivel,90 Elbow     | 1              | 80-0132 |
| 14                           | Tube,5/32"x10/32,UNF,Male Connector     | 3              | 80-0138 |
| 15                           | Tube,1/2"x3/8",NPTM,Male Connector      | 1              | 80-0131 |
| 16                           | Elbow - 1/2" Alum Body                  | 1              | 80-0095 |
| 17                           | Terminal Strip Assembly                 | 1              | 80-0124 |
| 18                           | Fuse 250V, 2A                           | 1              | 80-0100 |
| 19                           | Relay Socket                            | 1              | 80-0119 |
| 20                           | Tube,3/8"x3/8",NPTM,Swivel,90 Elbow     | 3              | 80-0135 |
| 21                           | Plug - 3/8" Brass                       | 1              | 80-0115 |
| 22                           | Connector - 3/8" Brass Bulkhead         | 2              | 80-0092 |
| 23                           | Tube,3/8"x3/8",NPTM,Male Connector      | 2              | 80-0134 |
| 24                           | Filter - 3/8" Colescent                 | 1              | 80-0097 |
| 25                           | Elbow - 3/8" Brass Street 90            | 1              | 80-0096 |
| 26                           | Regulator - 3/8" w/gauge                | 1              | 80-0118 |
| 27                           | Tube,3/8"x3/8",NPTM,Swivel,Male Run Tee | 1              | 80-0136 |
| 28                           | Valve - 3/8" Brass Ball                 | 1              | 80-0141 |
| 29                           | Nipple - 3/8" Brass Close Hex           | 3              | 80-0113 |
| 30                           | Nipple - 1/2" Stainless Close           | 1              | 80-0110 |
| 31                           | Tube, 1/2"x1/2", NPT, 90 Elbow          | 1              | 80-0130 |

**EXPLODED VIEW & PARTS LISTING**

**SANIFLO<sup>TM</sup> VC8**

**EXPLODED VIEW**

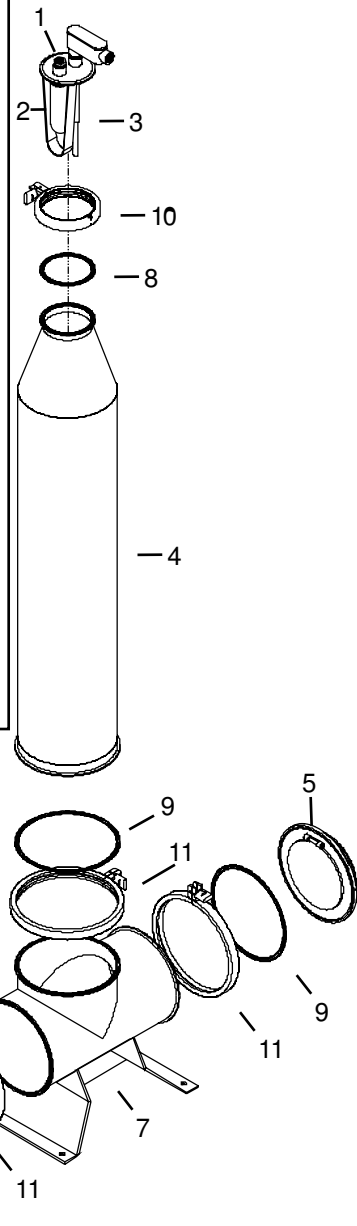
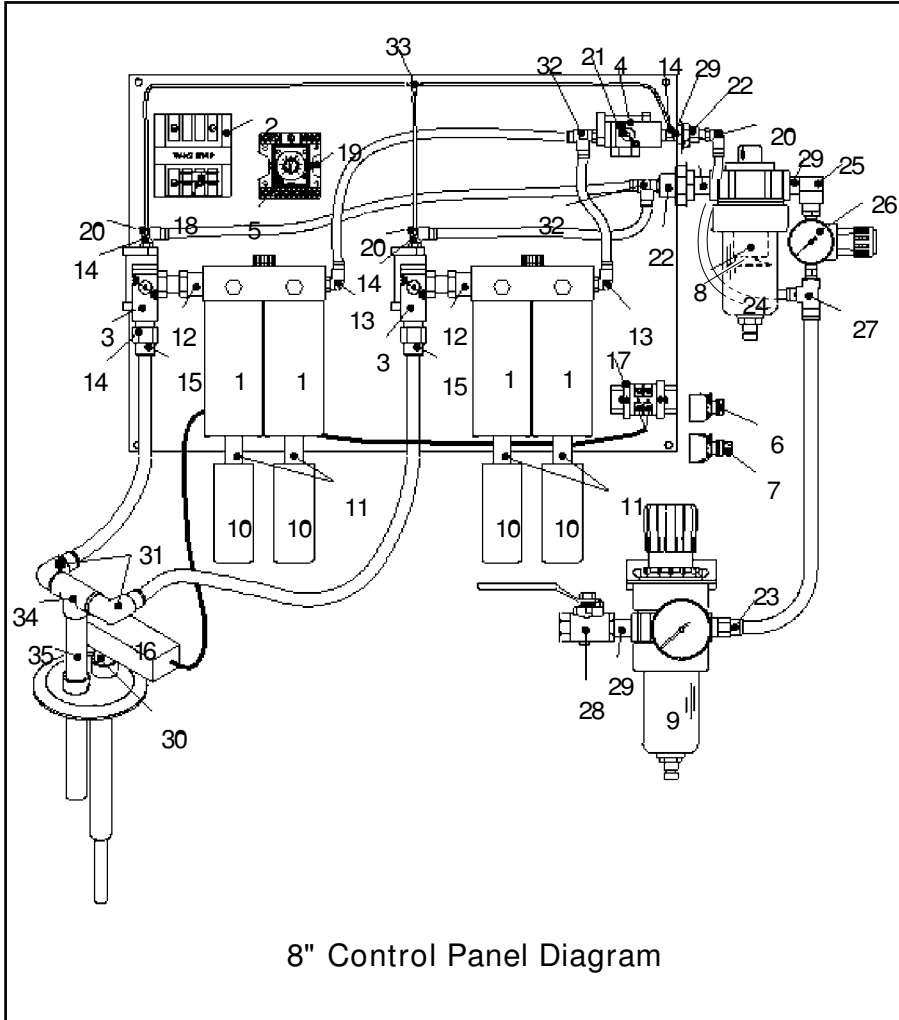

**EXPLODED VIEW & PARTS LISTING**

**SANIFLO<sup>TM</sup> VC8**

**PARTS LISTING**

| VC8 PUMP COMPONENTS |  |               |                      |                      |
|---------------------|--|---------------|----------------------|----------------------|
| Item                | Part Description                                   | Qty. Per Pump | VC8/SS/SS/TF/072 P/N | VC8/SS/SS/FB/072 P/N |
| 1                   | Cap - Water Heated Sensor                          | 1             | 80-0088              | 80-0088              |
| 2                   | Diffuser Stainless Steel (Water-Heated Sensor Cap) | 1             | 80-0093              | 80-0093              |
| 3                   | Probe  | 1             | 80-0116              | 80-0116              |
| 4                   | Tube - 8" Reservoir                                | 1             | 80-0129              | 80-0129              |
| 5                   | Valve, Inlet Check, 8" x 6"                        | 1             | 80-0148              | 80-0148              |
| 6                   | Valve, Outlet, 8" x 4" Reducer                     | 1             | 80-0163              | 80-0163              |
| 7                   | Base - 8" Pump                                     | 1             | 80-0086              | 80-0086              |
| 8                   | Gasket - 4" FB Buna                                | 1             | N/A                  | 80-0101              |
| 8                   | Gasket - 4" Teflon                                 | 1             | 80-0152              | N/A                  |
| 9                   | Gasket - 8" FB Buna                                | 3             | 80-0151              | 80-0151              |
| 9                   | Gasket - 8" Teflon                                 | 3             | 80-0154              | 80-0154              |
| 10                  | Clamp - 4" H.D.                                    | 1             | 80-0089              | 80-0089              |
| 11                  | Clamp - 8" H.D.                                    | 3             | 80-0150              | 80-0150              |

| VC8 CONTROL PANEL COMPONENTS |   |                |         |
|------------------------------|---|----------------|---------|
| Item                         | Part Description                        | Qty. Per Panel | P/N     |
| 1                            | Vacuum Generator - Double               | 2              | 80-0139 |
| 2                            | Transformer (24V)                       | 1              | 80-0126 |
| 3                            | Valve - 3-Way MAC,(PE) 24V              | 1              | 80-0142 |
| 4                            | Valve - 3-Way MAC,(PI) 24V              | 1              | 80-0143 |
| 5                            | Timer Relay (24V)                       | 1              | 80-0125 |
| 6                            | Switch - Purge, w/ n/o & n/c Contact    | 1              | 80-0121 |
| 7                            | Switch - On/Off Switch with n/o Contact | 1              | 80-0120 |
| 8                            | Coalescent Filter Cartridge             | 1              | 80-0091 |
| 9                            | Regulator - 3/8" Filter,150 psi w/Gage  | 1              | 80-0117 |
| 10                           | Muffler                                 | 4              | 80-0109 |
| 11                           | Nipple - 3/8"x2 1/2", Stainless         | 4              | 80-0114 |
| 12                           | Nipple - 1/2"x3/8", Brass Male Reducing | 2              | 80-0111 |
| 13                           | Tube,3/8"x1/8",NPTM,Swivel,90 Elbow     | 2              | 80-0132 |
| 14                           | Tube,5/32"x10/32,UNF,Male Connector     | 4              | 80-0138 |
| 15                           | Tube,1/2"x3/8",NPTM,Male Connector      | 2              | 80-0131 |
| 16                           | LB - 1/2" Alum Body                     | 1              | 80-0095 |
| 17                           | Terminal Strip Assembly                 | 1              | 80-0124 |
| 18                           | Fuse 250V, 2A                           | 1              | 80-0100 |
| 19                           | Relay Socket                            | 1              | 80-0119 |
| 20                           | Tube,3/8"x3/8",NPTM,Swivel,90 Elbow     | 3              | 80-0135 |
| 21                           | Plug - 3/8" Brass                       | 1              | 80-0115 |
| 22                           | Connector - 3/8" Brass Bulkhead         | 2              | 80-0092 |
| 23                           | Tube,3/8"x3/8",NPTM,Male Connector      | 1              | 80-0134 |
| 24                           | Filter - 3/8" Colescent                 | 1              | 80-0097 |
| 25                           | Elbow - 3/8" Brass Street 90            | 1              | 80-0096 |
| 26                           | Regulator - 3/8" w/gauge                | 1              | 80-0118 |
| 27                           | Tube,3/8"x3/8",NPTM,Swivel,Male Run Tee | 1              | 80-0136 |
| 28                           | Valve - 3/8" Brass Ball                 | 1              | 80-0141 |
| 29                           | Nipple - 3/8" Brass Close Hex           | 3              | 80-0113 |
| 30                           | Nipple - 1/2" Stainless Close           | 1              | 80-0110 |
| 31                           | Tube, 1/2"x1/2", NPT, 90 Elbow          | 2              | 80-0130 |
| 32                           | Tube,3/8"x3/8",NPT,Swivel,Male Run Tee  | 2              | 80-0133 |
| 33                           | Tee - 5/32" Tube Union                  | 1              | 80-0123 |
| 34                           | Tee - 1/2" NPTF                         | 1              | 80-0122 |
| 35                           | Nipple - 1/2"x4"                        | 1              | 80-0112 |

NOTE: The VC8 pump is also available with a 152 mm (6" pump) discharge connection. To order this other option, use item numbers 80-1011 (VC8 w/Buna-N gaskets) or 80-1012 (VC8 w/PTFE gaskets). To order an 8" x 6" outlet reducer for a VC8 pump use item number 80-0149.

**DIRECTIONS FOR CONTROL PANEL**

**CAUTION:** Do not run pump without proper ground.

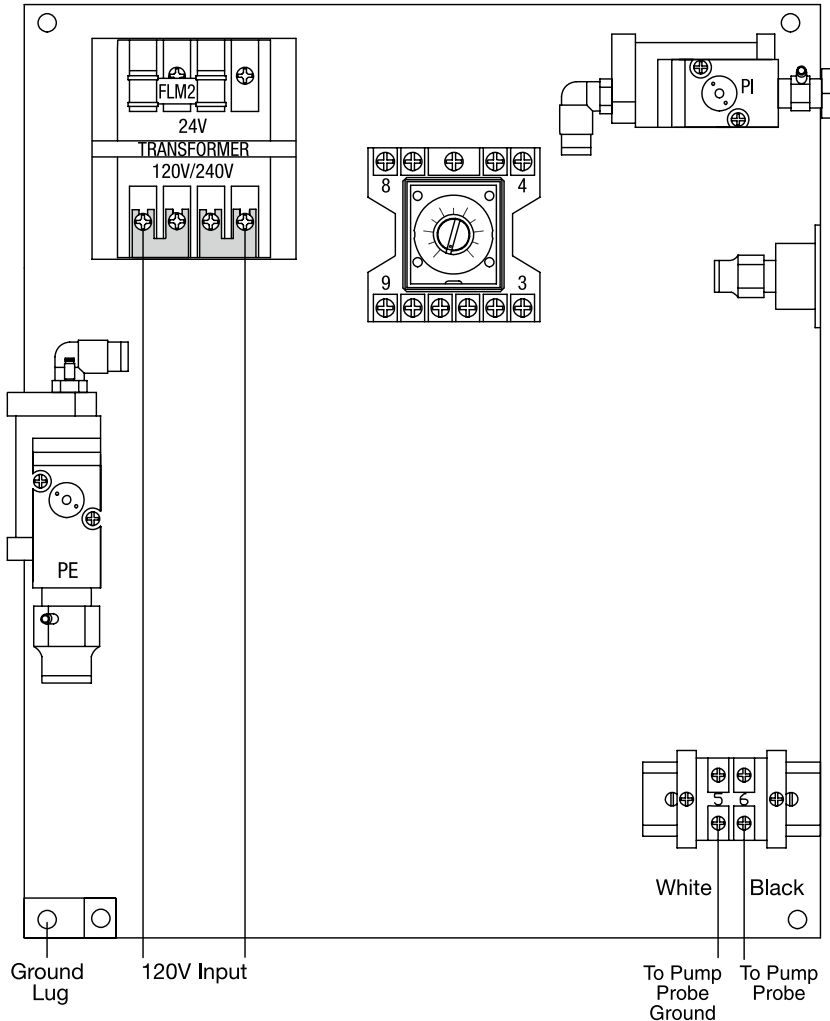

Ensure that all wiring is installed according to local codes and regulations by qualified electrical personnel. Follow these steps to connect the SANIFLOTM VC control panel.

1. Disconnect all electrical power to the circuits being serviced.
2. Install the metal jumpers to the screw terminals on the transformer as appropriate for either 120 VAC (Figure A) or 240 VAC (Figure B).
3. Connect the black or brown conductor into the terminal labeled L.
4. Connect the white or blue conductor into the terminal labeled N.
5. Connect the green or green/yellow conductor into the ground terminal.

Caution: When you install the conductors, make sure that the entire conductor is in the screw terminal and that there are no loose strands outside of the terminal. Only install one wire in each terminal.

6. Upon completion of installation, restore power to the circuit and verify proper installation.

**FIGURE A**  
**120 Volt Single Phase Hookup**

**FIGURE B**  
**240 Volt Single Phase Hookup**

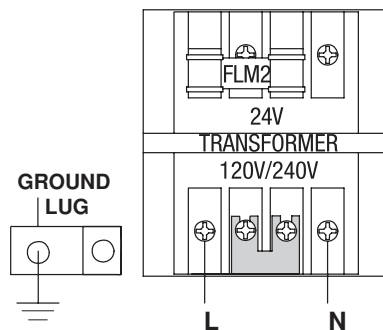
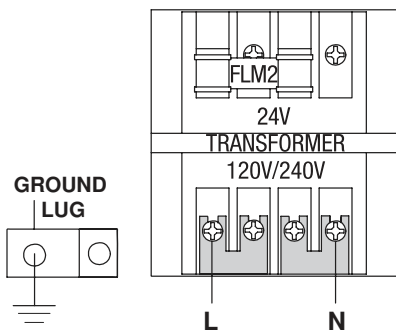

- 1) Set jumpers as shown
- 2) Connect positive, negative and ground wires as shown.

- 1) Set jumpers as shown
- 2) Connect positive, negative and ground wires as shown.

Be careful to install the correct conductor in the appropriate terminal. The color of the conductor wires varies depending on North American versus international standards.

1. Line wire (black by North American standards; brown by international standards)
2. Neutral wire (white by North American standards; blue by international standards)
3. Ground wire (green by North American standards; green/yellow by international standards)

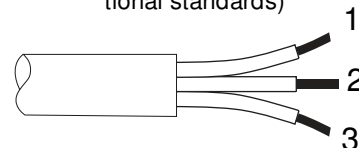

**NOTES**

---

**NOTES**

## WARRANTY

Each and every product manufactured by CAT Pump and Engineering, LLC is built to meet the highest standards of quality. Every pump is functionally tested to insure integrity of operation.

CAT Pump and Engineering, LLC warrants that pumps, accessories and parts manufactured or supplied by it to be free from defects in material and workmanship for a period of five (5) years from date of installation or six (6) years from date of manufacture, whichever comes first. Failure due to normal wear, misapplication, or abuse is, of course, excluded from this warranty.

Since the use of CAT pumps and parts is beyond our control, we cannot guarantee the suitability of any pump or part for a particular application and CAT Pump and Engineering, LLC shall not be liable for any consequential damage or expense arising from the use or misuse of its products on any application. Responsibility is limited solely to replacement or repair of defective CAT pumps and parts.

All decisions as to the cause of failure are the sole determination of CAT Pump and Engineering, LLC.

Prior approval must be obtained from CAT for return of any items for warranty consideration and must be accompanied by the appropriate MSDS for the product(s) involved. A Return Goods Tag, obtained from an authorized CAT distributor, must be included with the items which must be shipped freight prepaid.

The foregoing warranty is exclusive and in lieu of all other warranties expressed or implied (whether written or oral) including all implied warranties of merchantability and fitness for any particular purpose. No distributor or other person is authorized to assume any liability or obligation for CAT Pump and Engineering, LLC other than expressly provided herein.

### PLEASE PRINT OR TYPE AND FAX

| PUMP INFORMATION  |             |                            |                   |
|---|-------------|----------------------------|-------------------|
| Item # _____  |             | Serial # _____             |                   |
| Company Where Purchased _____   |             |                            |                   |
| YOUR INFORMATION  |             |                            |                   |
| Company Name _____  |             |                            |                   |
| Industry _____  |             |                            |                   |
| Name _____  |             | Title _____                |                   |
| Street Address _____  |             |                            |                   |
| City _____  | State _____ | Postal Code _____          | Country _____     |
| Telephone _____   | Fax _____   | E-mail _____               | Web Address _____ |
| Number of pumps in facility? _____  |             | Number of CAT pumps? _____ |                   |
| Types of pumps in facility (check all that apply): <input type="checkbox"/> Diaphragm <input type="checkbox"/> Centrifugal <input type="checkbox"/> Gear <input type="checkbox"/> Submersible <input type="checkbox"/> Lobe |             |                            |                   |
| <input type="checkbox"/> Other _____  |             |                            |                   |
| Media being pumped? _____   |             |                            |                   |
| How did you hear of CAT Pump? <input type="checkbox"/> Trade Journal <input type="checkbox"/> Trade Show <input type="checkbox"/> Internet/E-mail <input type="checkbox"/> Distributor                                      |             |                            |                   |
| <input type="checkbox"/> Other _____  |             |                            |                   |